

HERITAGE HARDWARE

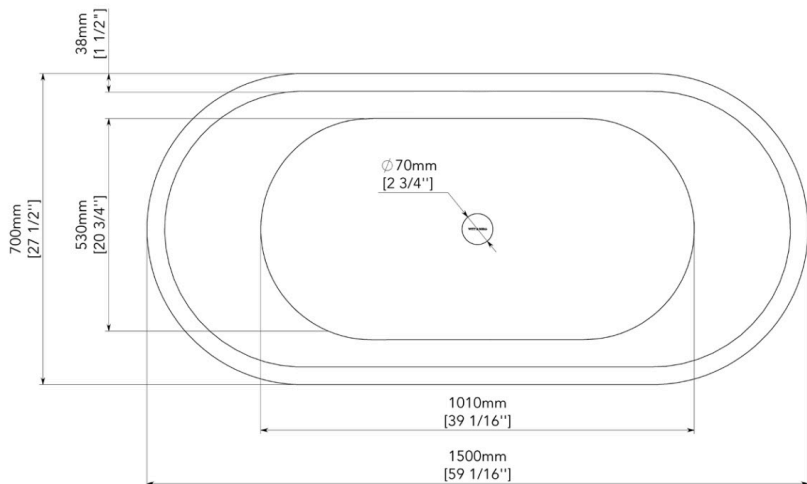
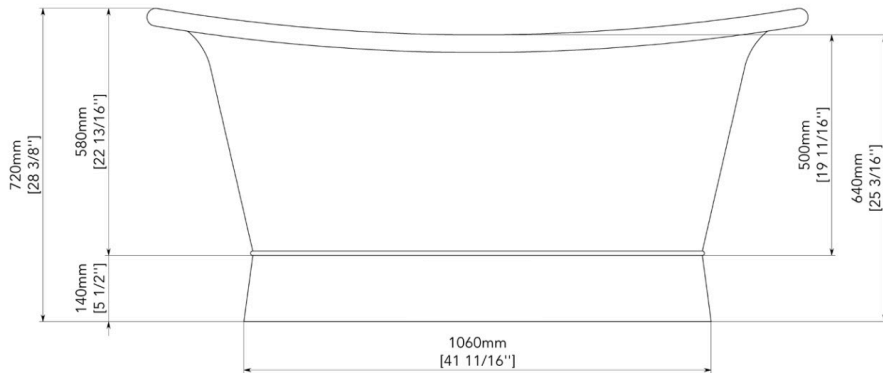

Sales Code:

Kensington Bath AC-PN-15

Description:

Antique Copper & Polished Nickel Bath

Product Dimensions

Length (mm): 1500
Width (mm): 700
Height (mm): 720
Nett Weight (kg): 40.5≈

Packaging Dimensions

Corrugated Box/Wooden Box

Length (mm): 1610
Width (mm): 800
Height (mm): 910
Gross Weight (kg): 65/90≈

Product Details

Product Material: Pure Copper
Volume (Ltr): 180
Waste Included: No
Material Thickness: 16 Gauge
Code: KB-AC-PN-15

Sales@heritagehardware.co.uk

www.heritagehardware.co.uk